

FICHE TECHNIQUE

GARDE CORPS STEEL LINE

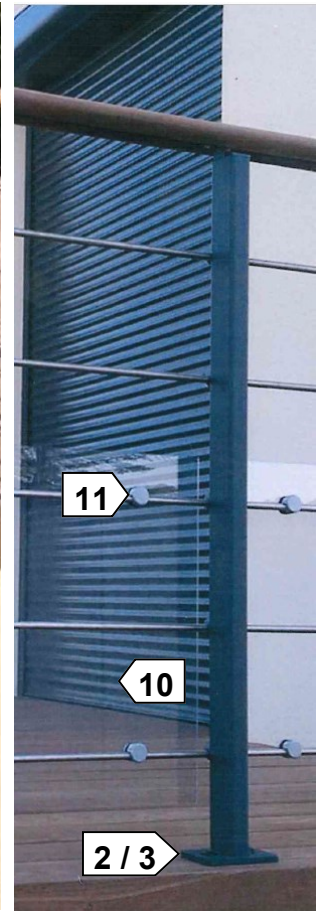

FOURNITURES GARDE CORPS					
POTEAU ACIER ELECTROZINGUE RAL 7016 POSE EN APPLIQUE	1		ML DE TUBES INOX A2-304 - Ø 10 mm	6	
POTEAU ACIER ELECTROZINGUE RAL 7016 POSE SUR LE DESSUS	2		SACHET 10 CAPUCHONS DE FINITION POLYPROPENE (pour tubes inox)	7	
KIT DE FIXATION POTEAU (2 goujons 10*95 ou 2 tirefonds 10*120)	3		SACHET 5 ANGLES VARIABLES 90° à 180 °+ colle	8	
ML DE MAIN COURANTE BOIS 35*70 MM KEBONY	4		SACHET 5 ASSEMBLEURS Ø 8*50 mm Ø 8*50 mm	9	
PLATINE FINITION MAIN COURANTE	5		ML DE PANNEAU PROTECTION VERRE ACRYLIQUE 4*1140*470 mm	10	
			SACHET DE 4 FIXATION PANNEAU (joints caoutchouc)	11	

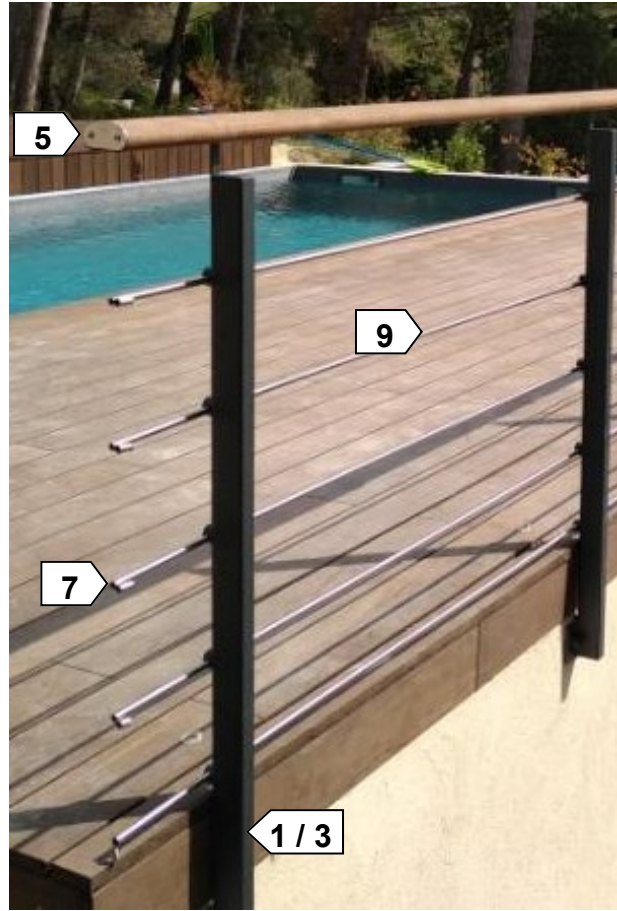
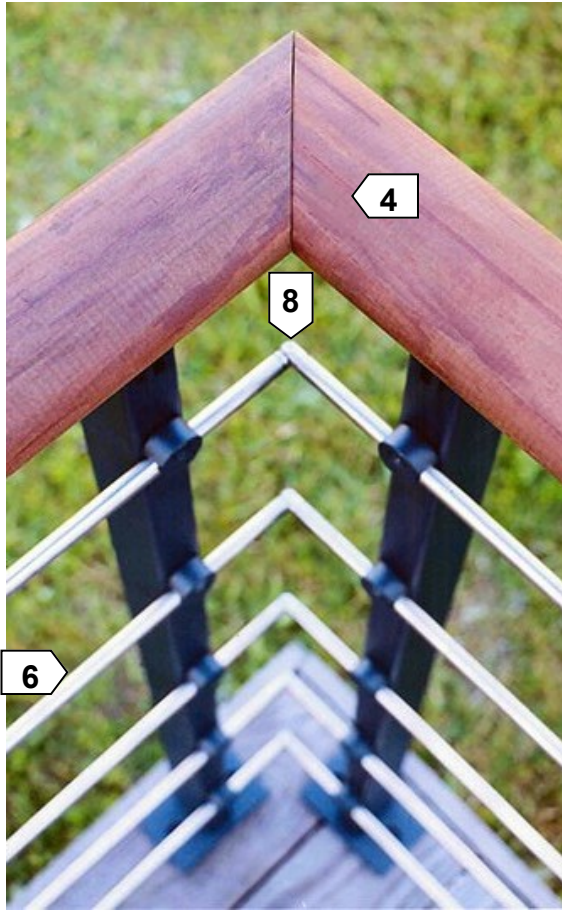

FICHE TECHNIQUE

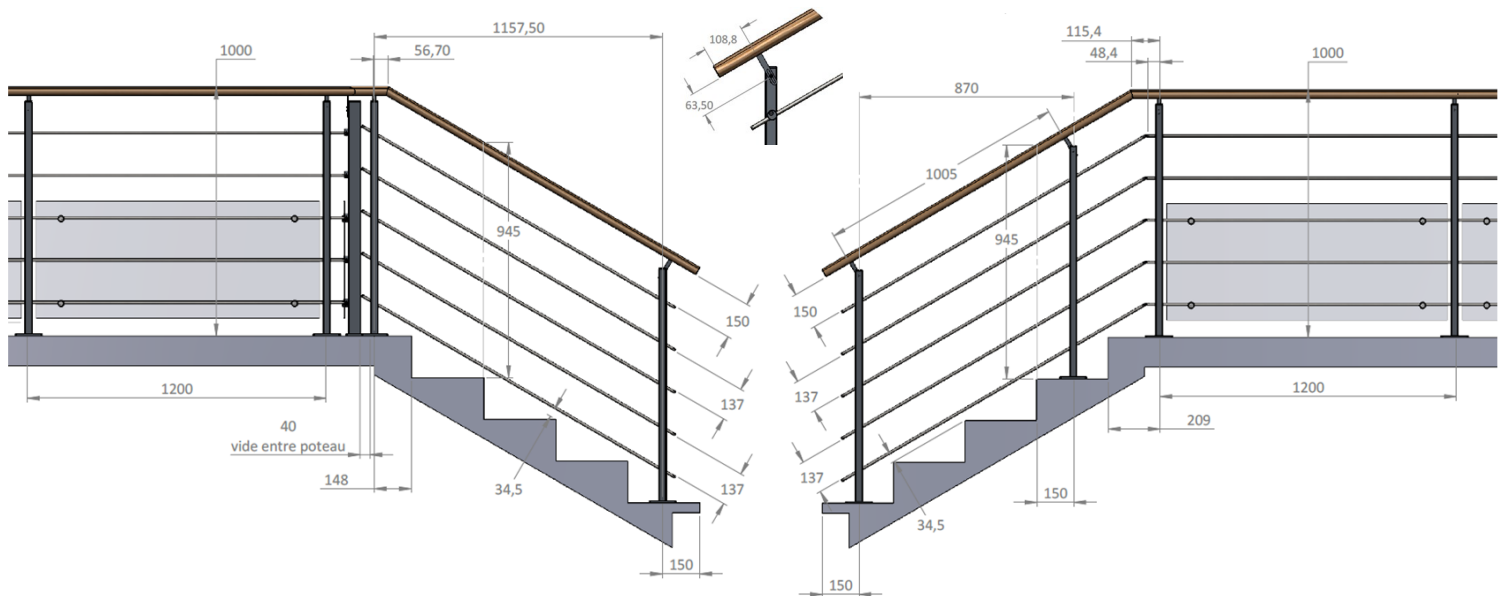

FICHE TECHNIQUE

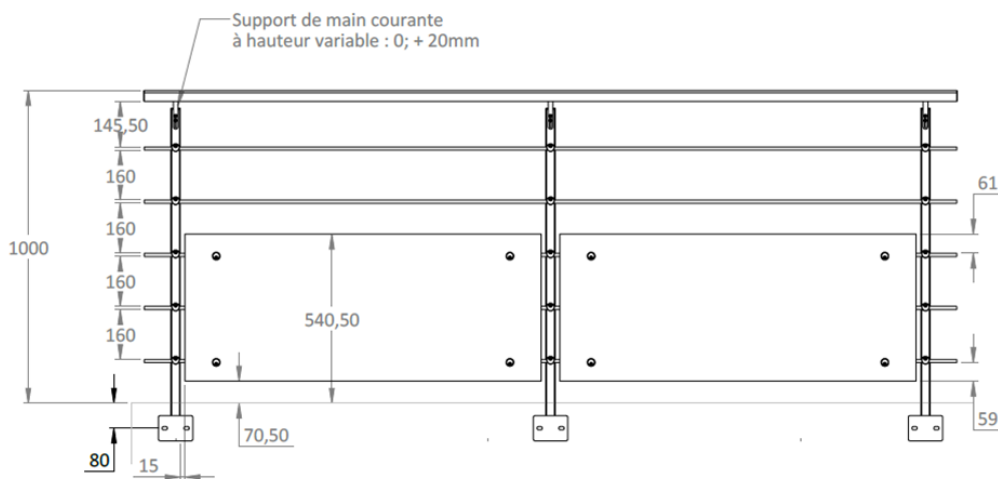
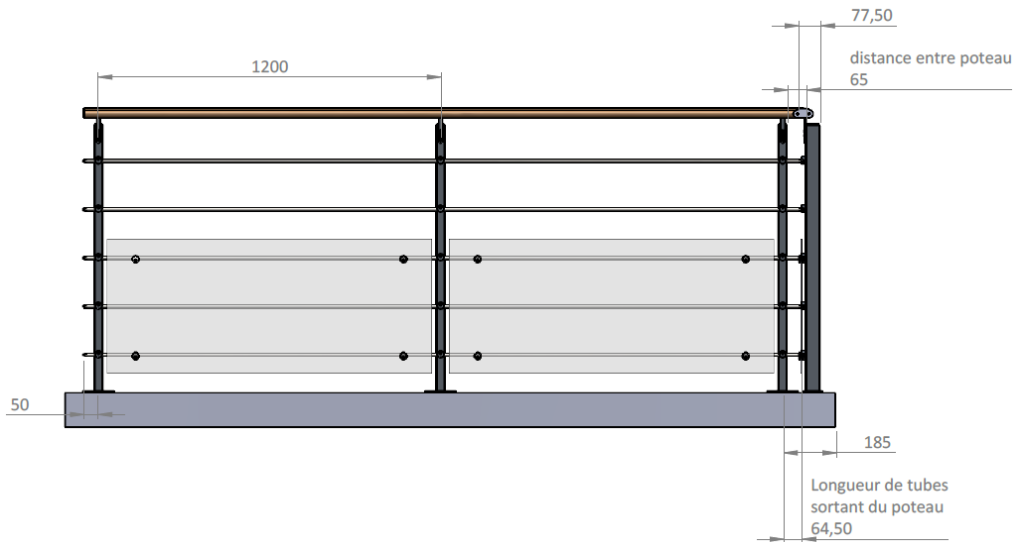
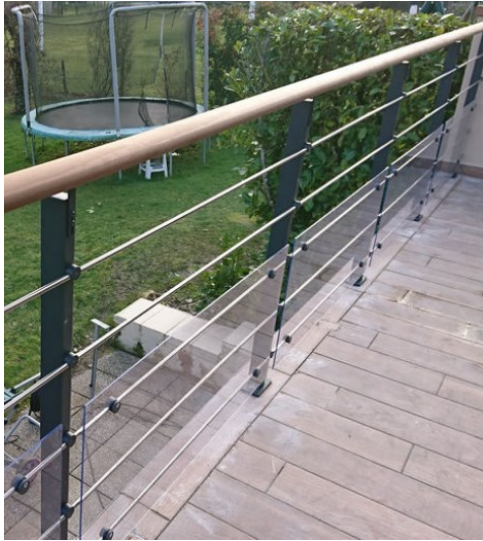

FICHE TECHNIQUE

